

Oct. 1, 1929.

O. BODEN

1,729,659

INTERNAL COMBUSTION ENGINE

Filed Sept. 13, 1927

2 Sheets-Sheet 1

Fig. 1.

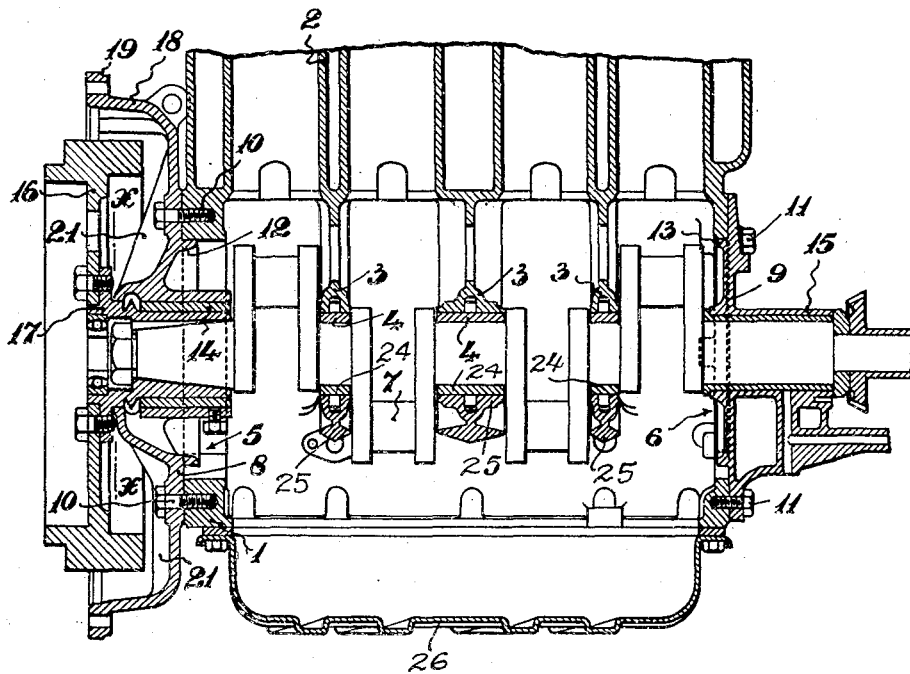

INVENTOR
OLIVER BODEN.
By *Richardson*
Leiser
Attorneys

Oct. 1, 1929.

O. BODEN

1,729,659

INTERNAL COMBUSTION ENGINE

Filed Sept. 13, 1927

2 Sheets-Sheet 2

Fig. 2.

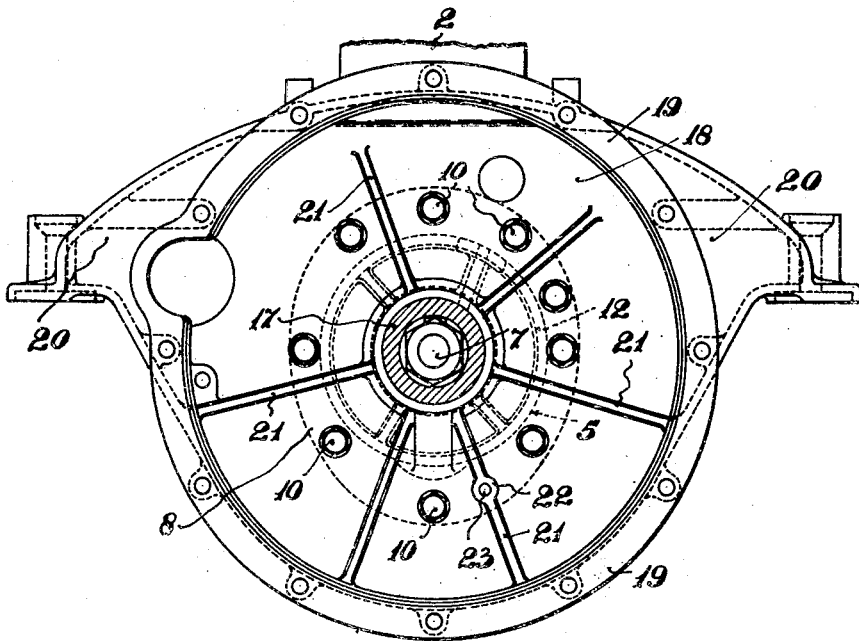
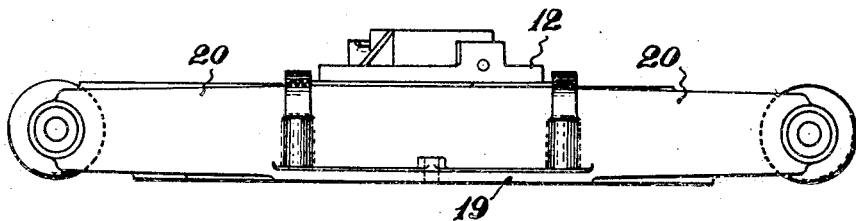

Fig. 3.



INVENTOR
OLIVER BODEN
By *Richardson & Co.*
Attorneys

UNITED STATES PATENT OFFICE

OLIVER BODEN, OF BIRMINGHAM, ENGLAND, ASSIGNOR TO WOLSELEY MOTORS (1927)
LIMITED, OF BIRMINGHAM, ENGLAND, A COMPANY OF GREAT BRITAIN

INTERNAL-COMBUSTION ENGINE

Application filed September 13, 1927, Serial No. 219,198, and in Great Britain August 15, 1927.

This invention relates to internal combustion engines of that type having a crank-case provided at one or each end with a crank-shaft main bearing carried by a detachable cover-plate adapted to close an opening in the end of the crank-case, such opening being of such a size as to admit of the crank-shaft being inserted endwise therethrough prior to the attachment of the said cover-plate.

In engines having crank-cases of the above construction, the housing enclosing the fly-wheel at the one end of the crank-case, has been cast integral with the body of the crank-case, which has also carried the engine attachment brackets; but according to the present invention the said fly-wheel housing is carried by or made integral with the detachable cover-plate at the fly-wheel end of the crank-case. This construction simplifies the casting of the crank-case and the subsequent machining thereof and facilitates the assembly of the crank-shaft and other parts. It also permits of employing a lighter material for the housing than is used for the body of the crank-case, and thus reduces the total weight of the engine, at the same time lessening the cost of production.

A further feature of the invention is that the engine attachment brackets are formed integral with the fly-wheel housing and cover-plate units.

Figure 1 of the accompanying drawings represents a longitudinal section through an engine crank-case and fly-wheel housing in accordance with the present invention.

Figure 2 is a cross-section on line 2—2, Figure 1, with the fly-wheel removed, showing the combined fly-wheel housing and cover-plate in elevation.

Figure 3 is a plan of the combined fly-wheel housing and cover-plate.

The crank-case 1 is cast in one piece either integral with the cylinder block 2, or as a separate unit. It may also have cast with it the housings 3 for the upper halves 4 of the intermediate crank-shaft bearings. In opposite ends of the crank-case large suitably-shaped openings 5, 6, are provided to enable the crank-shaft 7 to be inserted endwise

therethrough prior to being engaged with the said upper halves 4 of the bearings, the said openings being adapted to be closed, after the introduction of the crank-shaft, by means of detachable cover plates 8, 9, secured to the ends of the crank-case body by bolts 10, 11, respectively. The said cover plates 8, 9, have register flanges or shoulders 12, 13, engaging within the openings 5, 6, of the crank-case, and carry bearing bushings 14, 15, for the main crank-shaft bearings. The fly-wheel 16 may be bolted to a flange on the sleeve 17 keyed on the tapered end of the crank-shaft. The crank-shaft intermediate bearings are completed by lower half-bearings 24 secured by detachable caps 25 attached to the housings 3 by the usual studs; the operation of applying the said lower half-bearings 24 and caps 25 being performed through the open bottom of the crank-case before the cover 26 it attached.

According to the present invention, the housing 18 which encloses or contains the fly-wheel 16 is cast integral with the cover-plate 8 so as to form an extension thereof, instead of being formed as an integral part of the crank-case body, as heretofore. The cover-plate 8 and housing 18 thus constitute a self-contained unit separate from the crank-case, so that this unit can be made of aluminum or other metal lighter than the material of which the crank-case is formed, thus reducing the total weight of the engine. The casting and machining of the crank-case is also simplified, and the assembly of the parts is facilitated.

The outer end of the housing 18 may have the usual flange 19 for bolting to the clutch housing or other suitable part. At opposite sides the housing 18 is provided with integral hollow or box-like extensions 20, 20, adapted to constitute the engine attachment brackets, which are thus part of the separate housing and cover-plate unit instead of being cast with the crank-case, as heretofore.

Suitable radial strengthening ribs or gusset stays 21 may be cast in the rear face of the cover-plate and housing 8, 18, and one of these ribs may be formed with an apertured boss 22 to receive a dowel 23 on the end of the crank-case.

Having fully described my invention, what I desire to claim and secure by Letters Patent is:—

1. A crank-case for an internal combustion engine having an end opening for the introduction of the crank-shaft, a detachable cover-plate adapted to close said opening and carrying a bearing for the crank-shaft, a fly-wheel housing cast integral with the said cover-plate, and engine brackets cast integral with the said fly-wheel housing and cover-plate.

2. A crank-case for an internal combustion engine comprising a body part cast in one piece throughout its depth and provided with integral end walls one of which has an opening therein through which the crank-shaft may be introduced, a detachable cover-plate adapted to be attached to said end wall of the crank-case to close the said opening therein and carrying an end bearing for the crank-shaft, a fly-wheel housing cast integral with the outer portion of said cover-plate, and laterally extending hollow boxlike attachment brackets cast integral with said fly-wheel housing and cover plate.

In testimony whereof I have hereunto set my hand.

OLIVER BODEN.

30

35

40

45

50

55

60

65